

FITTING INSTRUCTIONS

KIT AND DOOR SPECIFICATION

Kit Short Code	Door Thickness Range	Max. Door Width	kg
SIMHP120	25-50mm	1250mm	120kg

KIT CONTENTS

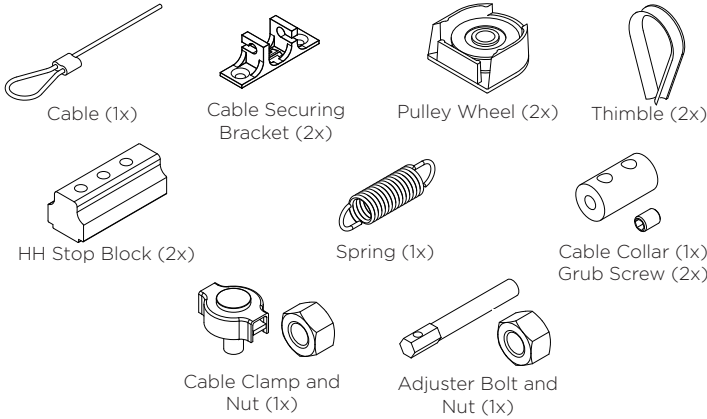

TOOLS REQUIRED

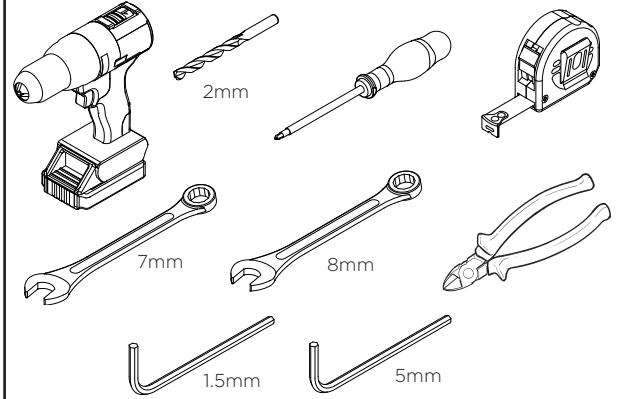

SYSTEM OVERVIEW

ELEVATED VIEW

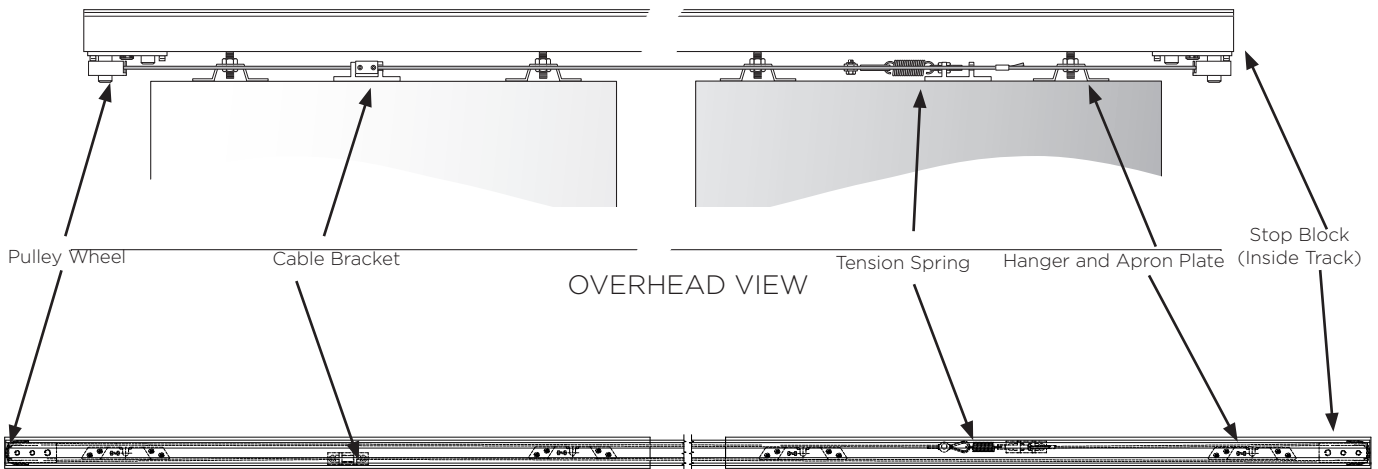

1 FIX PULLEY WHEELS INTO STOP BLOCKS.

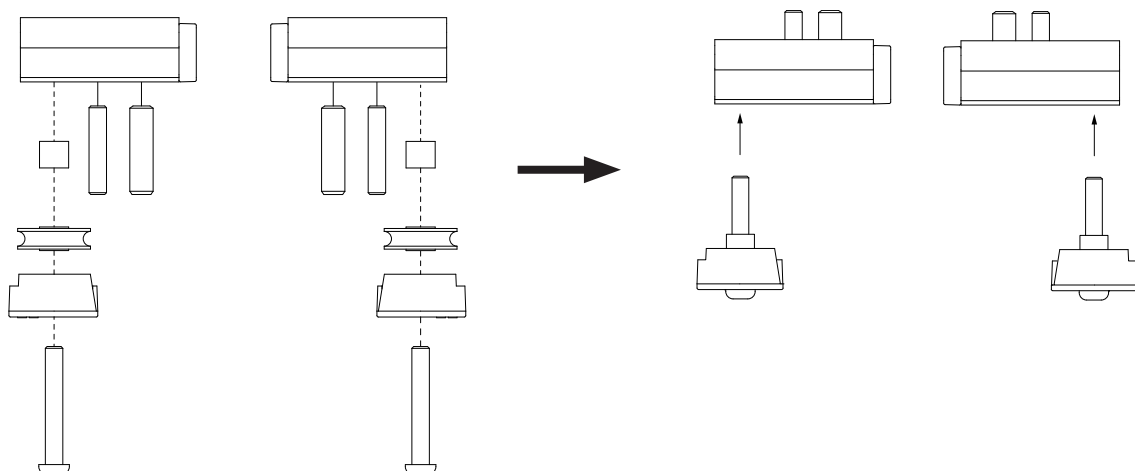

2 FIT DOOR BRACKETS TO BOTH DOORS.

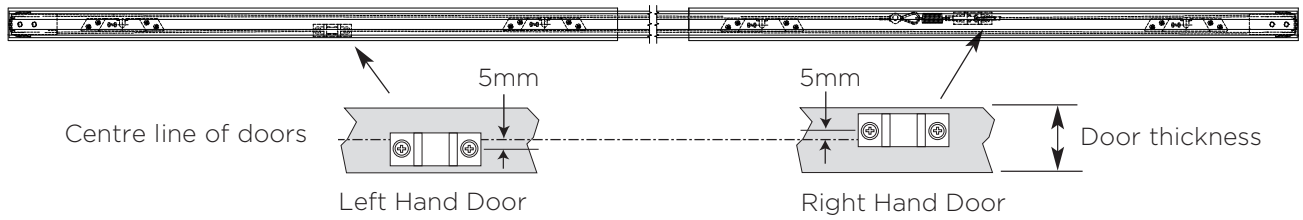

3 HOOK FIXED LOOP TO CABLE SECURING BRACKET.

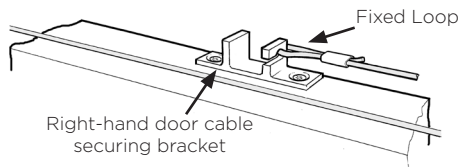

4 FEED CABLE THROUGH.

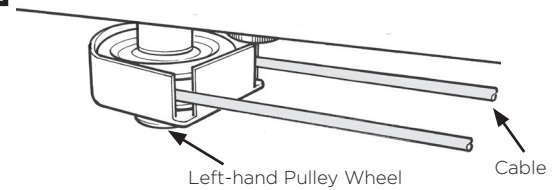

5 PLACE CABLE COLLAR INTO LH DOOR BRACKET. THREAD CABLE THROUGH.

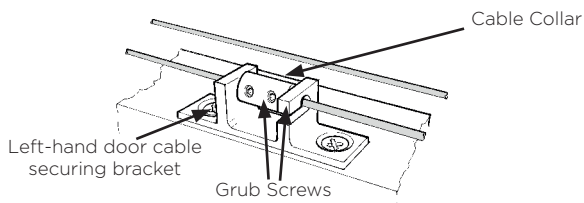

6 FEED CABLE THROUGH.

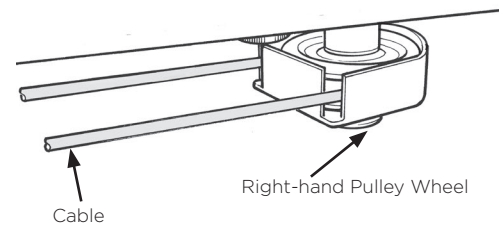

7 THREAD CABLE CLAMP ONTO CABLE, FORM LOOP AND INSERT THIMBLE. FEED CABLE BACK THROUGH CLAMP.

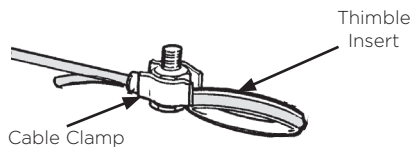

Note: Hold cable with a small amount of tension.

8 ATTACH CABLE TO THE DOOR.

- 1) Fit adjuster bolt onto RH door bracket with lock nuts.
- 2) Hook spring onto adjuster bolt. At other end hook onto cable loop.
- 3) Pull excess cable through clamp until spring starts to pull back. Tighten cable clamp nut to secure cable loop.
- 4) Cut off excess cable with cable cutters.
- 5) Alter adjuster nut to tension cable, removing sag in the cable. Lock off the nut.

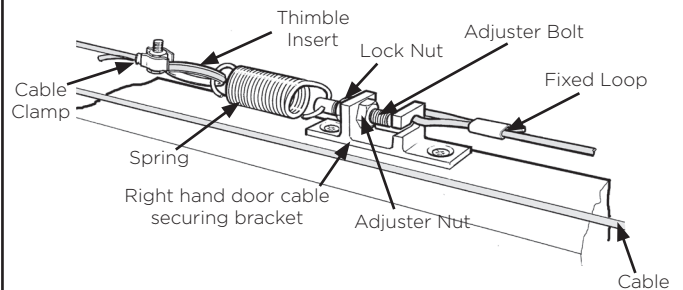

9 CLOSE DOORS. TIGHTEN GRUB SCREWS IN THE CABLE COLLAR TO SECURE DOORS IN PLACE. TEST THE OPERATION OF THE SYSTEM TO ENSURE IT IS WORKING CORRECTLY.

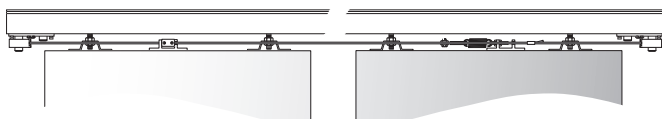

P C HENDERSON LTD
Durham Road, Bowburn,
Co. Durham,
DH6 5NG

UK SALES
t: +44 (0) 191 377 7345
e: sales@pchenderson.com
w: www.pchenderson.com

IRELAND SALES
t: +353 (0)1 643 6816
e: sales@pchenderson.ie
w: www.pchenderson.com

INTERNATIONAL SALES
t: +44 (0) 191 377 7346
e: international@pchenderson.com
w: export.pchenderson.com

370794
REV 3
Jun-23